

INSTALLATION INSTRUCTIONS

LUX[®]

CH200SA & CH400SA VERSATILE DELUXE LOW VOLTAGE THERMOSTAT

52010

CH200SA

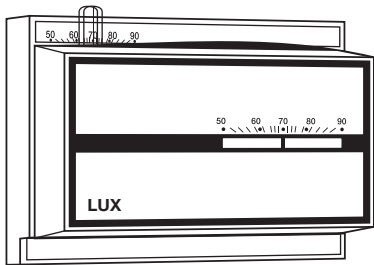

CH400SA

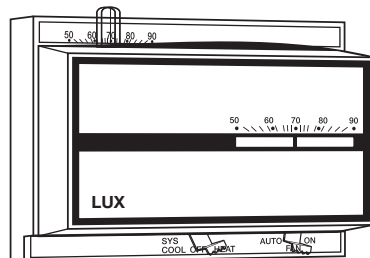

W A R N I N G

Not for use with compressors without time delays.

SPECIFICATIONS

24 Volts A.C.

Electrical Rating: 24 to 30 Volts A.C.

Heat Anticipator: 0.20 to 1.2 Amp. Max.

Cool Anticipator: 0 to 1.0 Amp. Max.

SELECTING THERMOSTAT LOCATION

The proper location of the room thermostat is most important to insure that it will provide a comfortable home temperature. Observe the following general rules when selecting a location:

1. Locate it about 5 ft. above the floor with a free flow of air.
2. Install it on a partitioning wall, not on an outside wall.
3. Never expose it to direct light or radiation from lamps, sun, fireplaces, etc.
4. Avoid locations close to doors that lead outside, windows, or adjoining outside walls.
5. Avoid locations close to radiators, warm air registers, or in the direct path of heat from them.
6. Make sure there are no pipes or duct work in that part of the wall chosen for the thermostat location.
7. Never locate it in a room that is warmer or cooler than the rest of the home such as kitchen or hallway or on the opposite side of the wall of a cold or unused room.
8. The living or dining room is normally a good location, provided there is no cooking range or refrigerator on opposite side of wall.

INSTALLATION

1. Remove cover from thermostat by pulling outward. Pull thermostat wires through small holes beside terminal screws on thermostat base and connect wires to proper terminal screws per wiring diagrams. Note that on some models wire leads may be connected to terminal screws on **back** of base.
2. **The thermostat can either be mounted to a standard horizontal outlet box or mounted directly to the wall.** Place level on top of thermostat base and mark hole locations for mounting screws. Push excess wire into wall or switch box and **plug up hole to prevent drafts from affecting thermostat operation.** Then attach thermostat base loosely to wall with the two screws provided.
3. Again place level on top of thermostat base to be sure it is level. Then tighten mounting screws securely and snap on thermostat cover.

HEATING ANTICIPATOR

The heating side of this thermostat is equipped with an adjustable heater. **Set heater indicator to match the current rating of the primary control.** The heater may be adjusted for current ratings from .2 to 1.2 Amp.

Additional adjustments, if necessary, may be made as follows:

BURNER CYCLES TOO LONG - Set adjustable heater to a slightly lower dial setting (1/2 division).

BURNER CYCLES TOO SHORT - Set adjustable heater to a slightly higher dial setting (1/2 division).

W A R N I N G

The Adjustable Heater (Heat Anticipator) WILL BURN OUT if 25V are applied directly to thermostat by shorting out the gas valve or primary control during testing or by incorrect wiring.

WIRING DIAGRAMS

Heating Systems

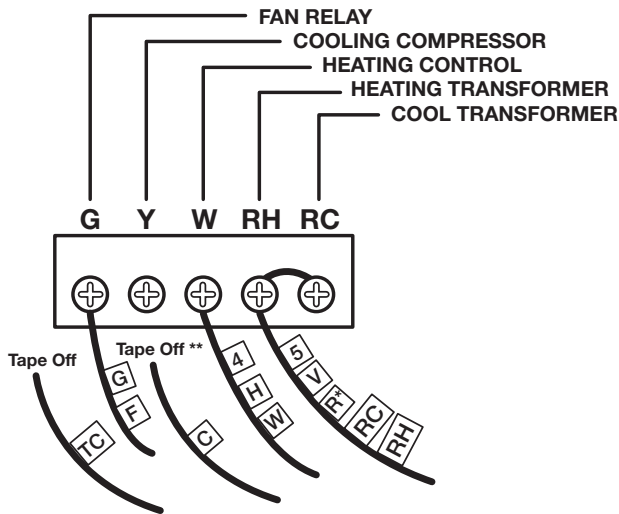

* If replacing a Honeywell TM-11, tape off wire "R"; connect wire "B" to terminal "RH."

** If replacing a Honeywell thermostat with a clock wire "C," tape off wire "C"

Cooling Systems

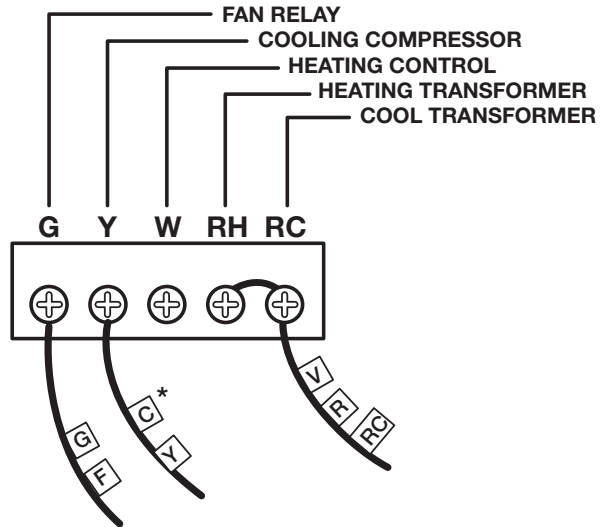

* If both Y and C wire are present, tape off "C" wire.

Heating/Cooling Systems 4- or 5-Wire with One Transformer

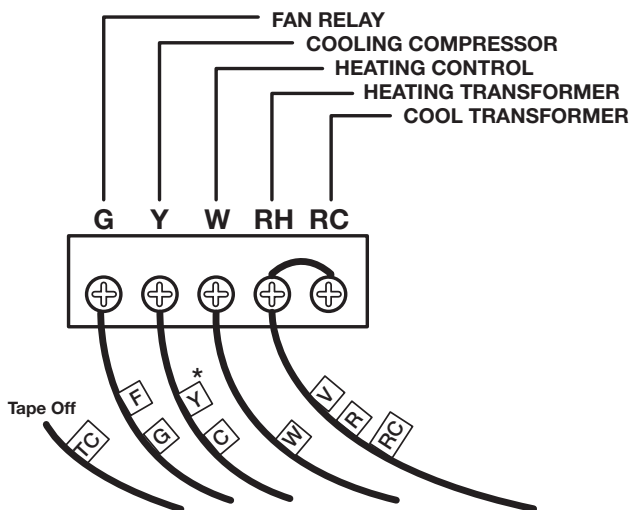

* If both Y and C wire are present, tape off "C" wire.

Heating/Cooling Systems 5-or 6- Wire with Two Transformers

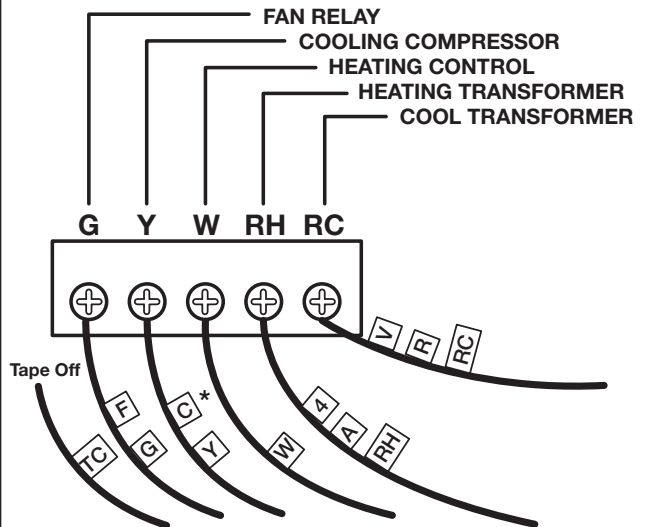

* If both Y and C wire are present, tape off "C" wire.

These diagrams below are provided for new installations or unreferenced wires.

**TYPICAL HOOKUP FOR 2-WIRE
24V HEATING SYSTEM AND
MILLIVOLT SYSTEM**

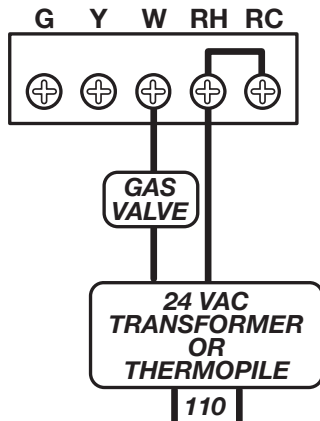

Figure 8

**TYPICAL HOOKUP FOR 3-WIRE
HEAT SYSTEM IF THIRD
WIRE IS FAN WIRE**

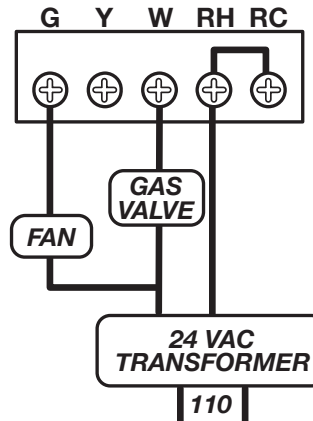

Figure 9

**TYPICAL COOLING AND
HEATING SYSTEM
(4-WIRE)**

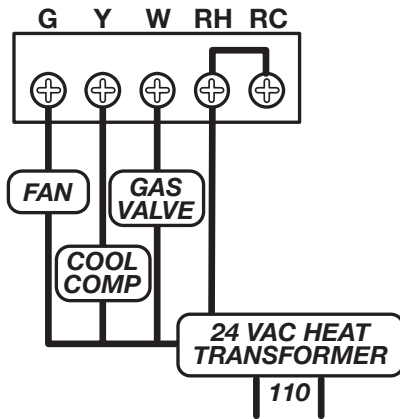

Figure 10

**TYPICAL COOLING AND
HEATING SYSTEM
(5-WIRE)**

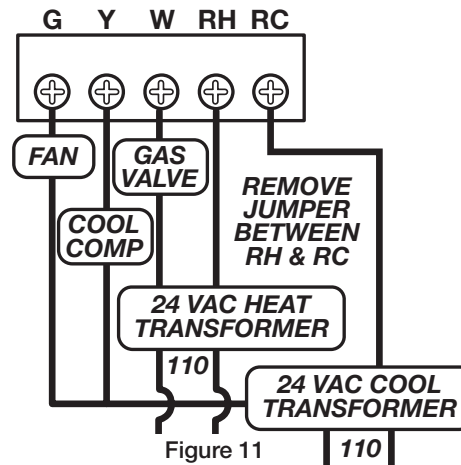

Figure 11

NOTE

if you have an electric system and the blower does not operate after installation, find the factory installed yellow wire currently attached to the "Y" terminal and move it to the "A" terminal on the sub-base.

TECHNICAL ASSISTANCE

If you have any problems installing or using this thermostat, please carefully and thoroughly review the instruction manual. If you require assistance, please contact our Technical Assistance Department at 856-234-8803 during regular business hours between 8:00AM and 4:30PM Eastern Standard Time, Monday through Friday. You can also receive technical assistance online anytime day or night at <http://www.luxproducts.com>. Our web site offers you answers to the most common technical questions, and also permits you to email your questions to our technical support staff at your convenience.

WARRANTY

Limited Warranty: If this unit fails because of defects in materials or workmanship within three years of date of original purchase, LUX Products Corporation will, at its option, repair or replace it. This warranty does not cover damage by accident, misuse, or failure to follow installation instructions. Implied warranties are limited in duration to three years from date of original purchase. Some states do not allow limitations on how long an implied warranty lasts, so the above limitation may not apply to you. Please return malfunctioning or defective units to the participating retailer from which purchase was made, along with proof of purchase. Please refer to "TECHNICAL ASSISTANCE" before returning thermostat. Purchaser assumes all risks and liability for incidental and consequential damage resulting from installation and use of this unit. Some states do not allow the exclusion of incidental or consequential damages, so the above exclusion may not apply to you. This warranty gives you specific legal rights and you may also have other rights which vary from state to state. Applicable in the U.S.A. only.

RECYCLING NOTICE



This product does not contain mercury. However, this product may replace a unit which contains mercury and should not be disposed of in the trash. Contact your local waste management authority for proper disposal instructions for mercury in a sealed glass tube. If you have any questions, please call (856) 234-8803